

TECHNICAL DATA SHEET

HYDRAULIC PAPER ROLL CLAMP

FHRC-1.3TF-F1150



DESCRIPTION

This forklift attachment is ideal for paper mills, printing, and packaging factories. The roll clamp allows easy handling and stacking of all types of paper rolls without pallets, ensuring efficiency, safety, and damage-free operation.

FEATURES

- ☒ With 360° rotation in both directions, it offers maximum flexibility.
- ☒ All above models are for 1.5~2.5T forklifts.
- ☒ Two additional hydraulic functions needed.
- ☒ Contact pads are offered according to different handling tasks program.



TECHNICAL DATA SHEET

HYDRAULIC PAPER ROLL CLAMP

FHRC-1.3TF-F1150

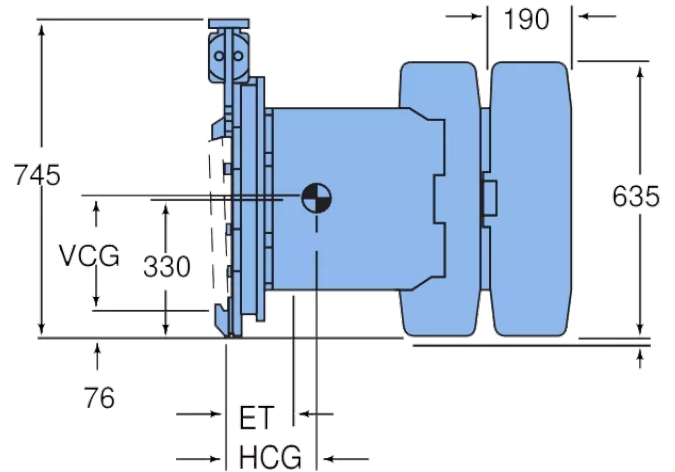
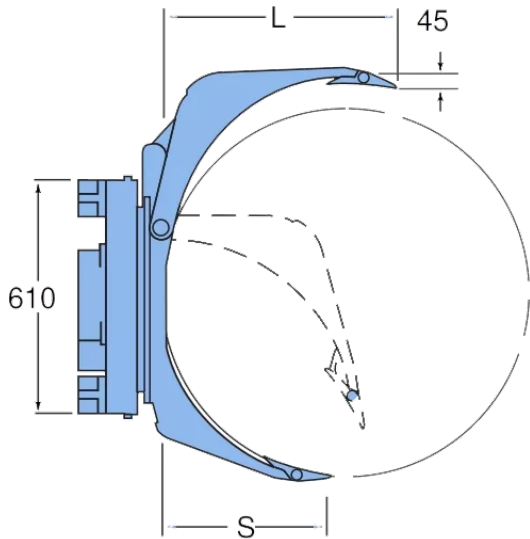

SPECIFICATIONS

CAPACITY (KG)	ROLL RANGE (MM)	MOUNTING CLASS	LONG ARM LENGTH (MM)	SHORT ARM LENGTH (MM)	VERTICAL CENTER OF GRAVITY VCG (MM)	HORIZONTAL CENTER OF GRAVITY HCG (MM)	EFFECTIVE THICKNESS ET (MM)	WEIGHT (KG)
1300	330-1150	II	680	510	320	215	135	340

CERTIFICATION

Manufactured strictly in accordance with the following standards:

STANDARD	DESCRIPTION
AS 3990-1993	Structural Steel for Mechanical Engineering
AS 2359.1-1995	Powered Industrial Trucks
AS 1554	Structural Steel Welding