



LIGHT-DUTY AIR WINCHES

MINI TA SERIES



MINI TA SERIES

LIGHT-DUTY AIR WINCHES



POWER & UTILITY for Multiple Tasks & Environments

The Mini TA Series of air winches (1,400- or 2,700-pound capacity) or “tuggers” are the utility players on construction and mining sites, as well as on oil and gas rigs. Compact envelopes and variable-speed operation make lifting, moving, and positioning materials fast and easy. They’re ideal in hazardous environments or when access to three-phase electrical sources is limited. You can count on smooth control and variable-speed operation for precise spotting and long lifts.

ASME B30.7 Compliance Available

- Contact Thern for details

Smooth Operation

- Anti-friction ball bearings, equipped with grease zerks, provide smooth operation and long life
- Variable-speed control smooths operation for precise spotting and long lifts

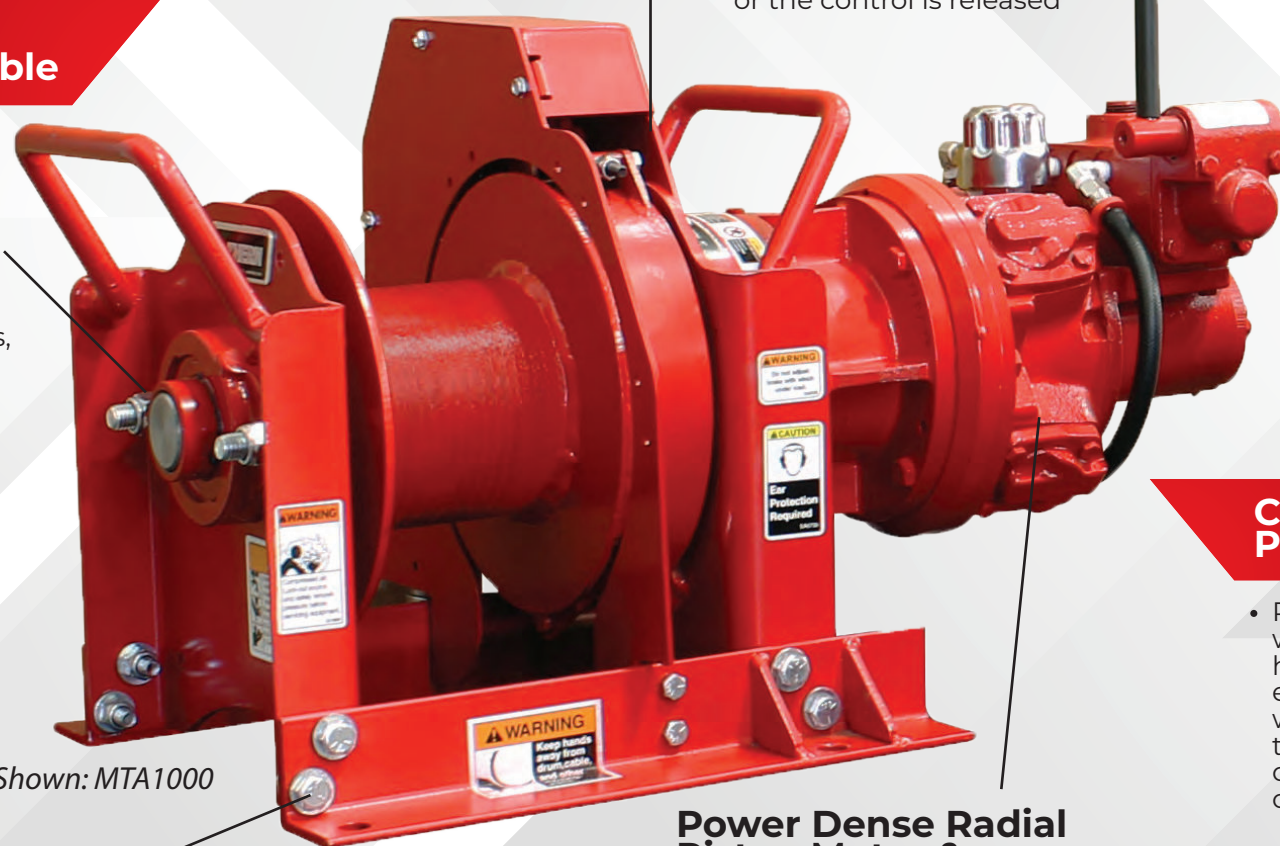

Product Shown: MTA1000

Automatic or Manual Band Brake

- Lever engaged/disengaged manual band brake for simple operation
- Automatic band brake enhances operator autonomy. Brake releases upon activation and sets when power is removed, or the control is released

Flexible Operation

- Available winch/valve-mounted manual control lever
- Operator-friendly, remote pendant control (up to 20 feet) with E-Stop reduces operator fatigue (due to vibration) and promotes freedom of movement for better load/task visibility

Corrosion Protection

- Red enamel coating with zinc-plated hardware resists the elements for longer wear. Optional three-part epoxy coating is available for corrosive environments

Power Dense Radial Piston Motor & Cycloidal Drive

- Internally lubricated for reliable operation and long service life
- Reversible, high-torque design allows precise yet flexible operation
- Drive design provides superior working speed, efficiency, and shock protection

Standard Convenience Features

- Bolt-together construction promotes easy maintenance, repair, and customization
- Lifting eyes with rounded edges provide easy positioning while extending sling life

PERFORMANCE

IMPERIAL					
Series	Load Rating	Power Supply	Line Speed	Drum Capacity	Clutch
MTA1000	1,400 lbs	1.35 hp	30 fpm	190 ft	No
MTA2000	2,700 lbs	3.5 hp	40 fpm	220 ft	No
MTA2000L	2,700 lbs	3.5 hp	40 fpm	580 ft	No

METRIC					
Series	Load Rating	Power Supply	Line Speed	Drum Capacity	Clutch
MTA1000	635 kg	1 kW	9.1 mpm	57.9 m	No
MTA2000	1,225 kg	2.6 kW	12.2 mpm	67.0 m	No
MTA2000L	1,225 kg	2.6 kW	12.2 mpm	176.7 m	No



NOTICE: These products are not for lifting people or things over people.

Refer to technical pages for detailed performance information.

MINI TA SERIES AIR WINCHES

Model MTA1000

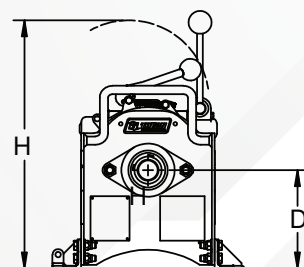
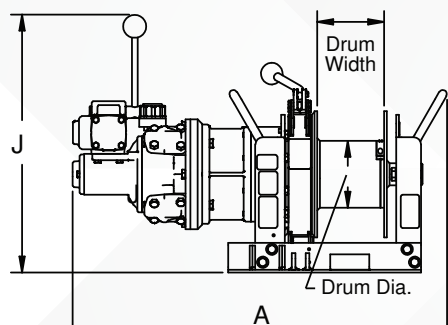
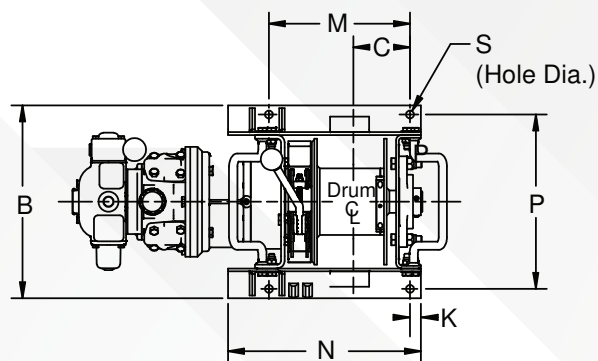

MTA1000 Load Rating

Load Rating 1st Layer	1,400 lb	635 kg
Load Rating Mid Drum	1,000 lb	453 kg
Load Rating Full Drum	800 lb	362 kg
Line Speed 1st Layer*	30 fpm	9 m/min
Line Speed Mid Drum*	41 fpm	12.5 m/min
Line Speed Full Drum*	52 fpm	15.8 m/min
Input HP	1.35 hp	1.0 kw
Max. Stall Pull 1st Layer**	2,600 lbs	1,179 kg
Pressure	90 psi	6.2 bar
Flow	60 scfm	1.69 m3/min
Pipe Inlet Size	0.5 in	12.7 mm
Hose Size	.75 in	19.0 mm

* Line speeds are estimated values based on testing and may vary based on conditions of air supply. Speeds shown are at max line pull.

** Estimated value

MTA1000 & MTA2000 Minimum Fleet Angle Distances

Model	Drum Diameter		Flange Diameter		Drum Width		Fleet Angle Distance	
	(in)	(mm)	(in)	(mm)	(in)	(mm)	(ft)	(m)
MTA1000	4.5	114	8.5	216	4.5	114	7.16	2.18
MTA2000-5	7	177.8	13.75	349	5.0	127	7.95	2.4
MTA2000-13	7	177.8	13.75	349	13.0	330	20.67	6.3

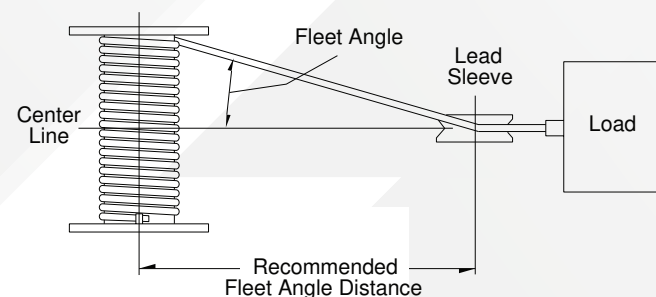

Model MTA2000

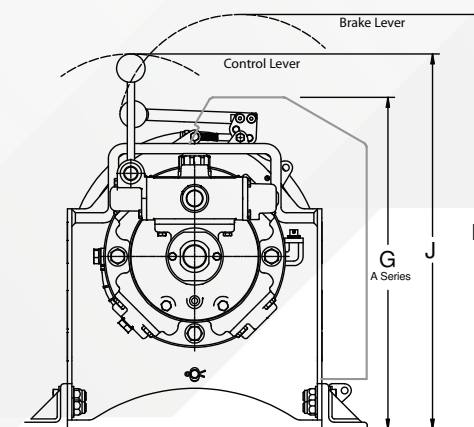
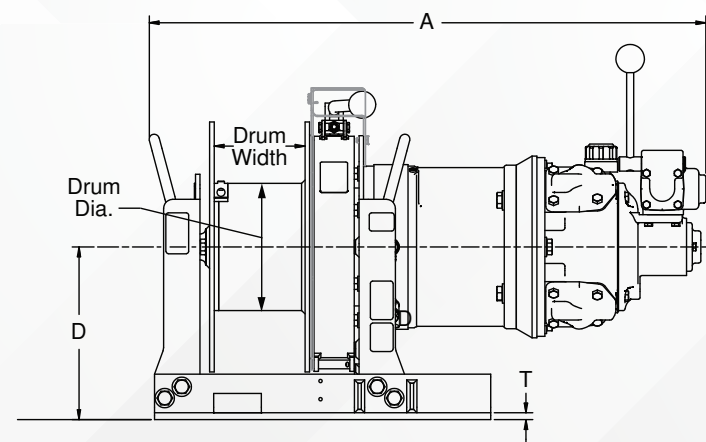
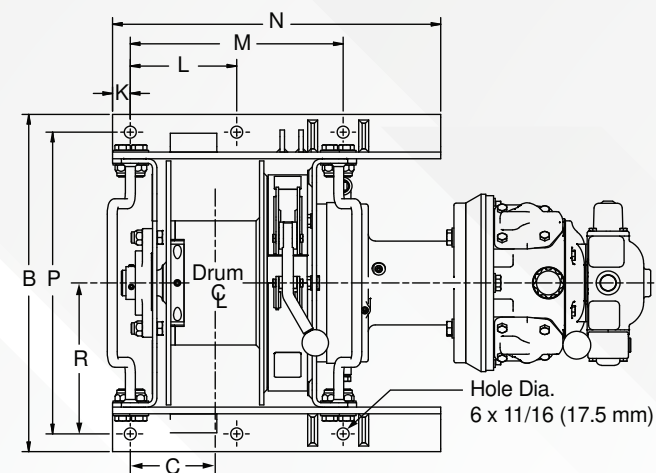

MTA2000 Load Rating

Load Rating 1st Layer	2,700 lb	1,224 kg
Load Rating Mid Drum	2,000 lb	907 kg
Load Rating Full Drum	1,600 lb	725 kg
Line Speed 1st Layer*	40 fpm	12.2 m/min
Line Speed Mid Drum*	54 fpm	16.4 m/min
Line Speed Full Drum*	67 fpm	20.4 m/min
Input HP	3.5 hp	2.6 kw
Max. Stall Pull 1st Layer**	5,800 lbs	2,630 kg
Pressure	90 psi	6.2 bar
Flow	140 scfm	3.96 m3/min
Pipe Inlet Size	0.75 in	19.0 mm
Hose Size	1.0 in	25.4 mm

* Line speeds are estimated values based on testing and may vary based on conditions of air supply. Speeds shown are at max line pull.

** Estimated value

MTA1000 Drum Capacities

Drum Width		4.5 in (114 mm)							
Rope Diameter	Breaking Strength*	1st Layer		Mid Drum		Full Drum			
(in)	(mm)	(lb)	(kg)	(ft)	(m)	(ft)	(m)	(ft)	(m)
1/4	6.35	7,000	3,175	16	4.8	87	26.5	190	57.9

* Values based on 7x19 galvanized aircraft cable wire rope.

MTA2000 Drum Capacities*

Drum Width	Rope Diameter	Breaking Strength**	1st Layer		Mid Drum		Full Drum				
(in)	(mm)	(lb)	(kg)	(ft)	(m)	(ft)	(m)	(ft)	(m)		
5	127	3/8	9.5	15,100	6,849	17	5.1	100	30.4	220	67
13	330	3/8	9.5	15,100	6,849	55	16.7	260	79.2	580	176

* Drum capacity is based on a drum flange clearance at the top layer per ASME B30.7.
** Values based on 6x37 IWRC EIPS wire rope.

MTA1000 Series Winch Dimensions

Model	A		B		C		D		H		J		K		M		N		P		S (hole dia.)		Ship Wt.	
	(in)	(mm)	(in)	(mm)	(in)	(mm)	(in)	(mm)	(in)	(mm)	(in)	(mm)	(in)	(mm)	(in)	(mm)	(in)	(mm)	(in)	(mm)	(in)	(mm)	(lb)	(kg)
MTA1000 4M1	25.25	641	13	330	3.81	97	6.625	168	16.75	425	17.375	441	0.75	19	9.5	241	13	330	11.75	298	.56	14	124	56
MTA1000 4A1	25.25	641	13	330	3.81	97	6.625	168	-	-	17.375	441	0.75	19	9.5	241	13	330	11.75	298	.56	14	133	60
MTA1000 4A3	25.25	641	13	330	3.81	97	6.625	168	-	-	-	-	0.75	19	9.5	241	13	330	11.75	298	.56	14	153	69

Dimensions are for reference only and subject to change without notice. Please contact Thern for exact dimensions.

MTA2000 Series Winch Dimensions

Model	A		B		C		D		G		H		J		K		L		M		N		P		S (hole dia.)		T		Ship Wt.	
	(in)	(mm)	(in)	(mm)	(in)	(mm)	(in)	(mm)	(in)	(mm)	(in)	(mm)	(in)	(mm)	(in)	(mm)	(in)	(mm)	(in)	(mm)	(in)	(mm)	(in)	(mm)	(in)	(mm)	(in)	(mm)	(lb)	(kg)
MTA2000-5M1	30.625	778	19	482	4.781	121	9.5	241	-	-	22.8	579	20.625	524	1.0	25.4	6	152	12	305	18.5	470	17	432	.6875	17.5	.375	9.5	282	128
MTA2000-5A1	30.625	778	19	482	4.781	121	9.5	241	18.25	463	-	-	20.625	524	1.0	25.4	6	152	12	305	18.5	470	17	432	.6875	17.5	.375	9.5	294	134
MTA2000-5A3	30.625	778	19	482	4.781	121	9.5	241	18.25	463	-	-	-	-	1.0	25.4	6	152	12	305	18.5	470	17	432	.6875	17.5	.375	9.5	315	143
MTA2000-13M1	30.625	778	19	482	8.781	223	9.5	241	-	-	22.8	579	20.625	524	1.0	25.4	10	254	20	508	26.5	673	17	432	.6875	17.5	.375	9.5	320	145
MTA2000-13A1	30.625	778	19	482	8.781	223	9.5	241	18.25	463	-	-	20.625	524	1.0	25.4	10	254	20	508	26.5	673	17	432	.6875	17.5	.375	9.5	332	151
MTA2000-13A3	30.625	778	19	482	8.781	223	9.5	241	18.25	463	-	-	-	-	1.0	25.4	10	254	20	508	26.5	673	17	432	.6875	17.5	.375	9.5	353	160

Dimensions are for reference only and subject to change without notice. Please contact Thern for exact dimensions.



Stratalign Limited

6 Harbour Ridge Drive
Wiri, Auckland
2104
New Zealand

09 263 7725
sales@stratalign.co.nz
www.stratalign.co.nz