

## TECHNICAL DATA SHEET

BALKEN G2 ELECTRIC TROLLEY - SINGLE SPEED

MODEL: DET-XXX



### DESCRIPTION

Balken Generation 2 - Industrial 400V Single Speed Electric Trolley with a 250kg - 5000kg capacity.

### FEATURES

- ❑ Balken Generation 2 Electric Trolley manufactured for Stratalign by Delta Hoists, Netherlands.
- ❑ Built to European Standard Machinery Directive 2006/42/EC. Supplied with test certificate, CE declaration of conformity and operating instructions.
- ❑ Made to the EU Electrical Safety Standard BS EN 60204-32:2008
- ❑ Design Verified by NZ registered Chartered Professional Engineer.
- ❑ Electric trolley is IP54 rated.
- ❑ Balance support wheels enable smooth travelling along the beam
- ❑ Safety bars serve as fall, breaking and impact protection. Additionally equipped with tilting protection.
- ❑ Permanently lubricated, ball bearing mounted wheels allow for smooth traversing.
- ❑ Suitable for most I and H beam profiles.



# TECHNICAL DATA SHEET

BALKEN G2 ELECTRIC TROLLEY - SINGLE SPEED

MODEL: DET-XXX

## SPECIFICATIONS

MODEL	CAPACITY kg	TRAVERSING SPEED m/min	DUTY CYCLE %	POWER OUTPUT kW	BEAM WIDTH mm	MIN. RADIUS m	WHEEL DIAMETER mm	NET WEIGHT kg
DET-250	250	13.5	40	0.2	74-300	1	68	33
DET-500	500	13.5	40	0.2	74-300	1	68	33
DET-1000	1000	13.5	40	0.2	74-300	1	68	33
DET-2000	2000	13.5	40	0.4	74-300	1.2	75	40
DET-3000	3000	13.5	40	0.4	100-310	1.6	96	53
DET-5000	5000	13.5	40	0.75	100-310	1.8	110	62

## DIMENSIONS

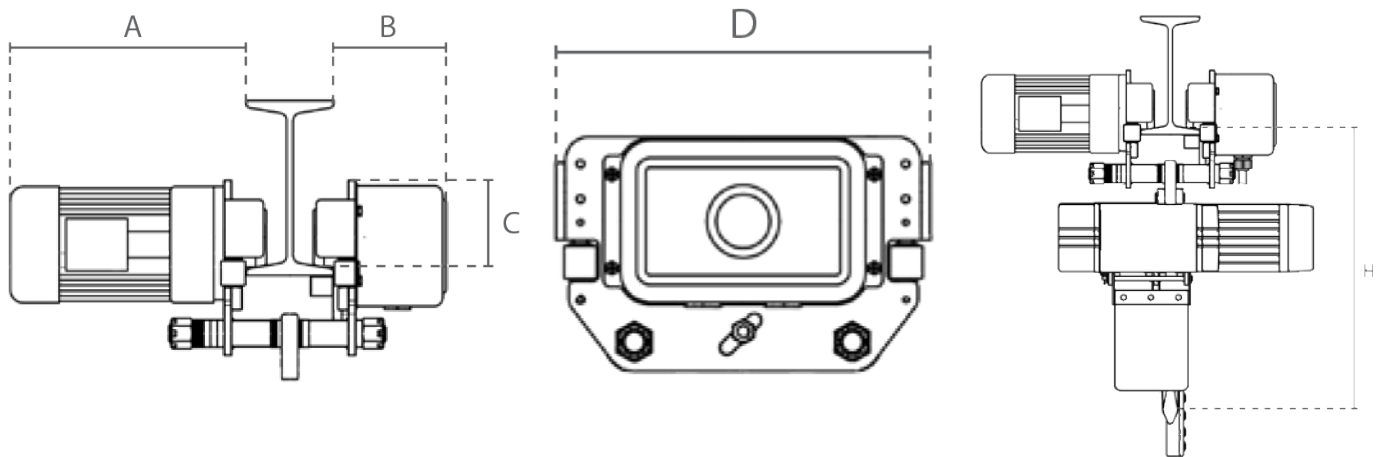

MODEL	TROLLEY DIMENSIONS (MM)				
	A	B	C	D	H
DET-250	336	131	97	320	438
DET-500	336	131	97	320	480
DET-1000	336	131	97	340	578
DET-2000	338	132	113	340	670
DET-3000	316	139	132	386	710
DET-5000	318	141	130	426	870