

## TECHNICAL DATA SHEET

JIB (SWING ARM BOOM) - 2000KG

FJA-19-468

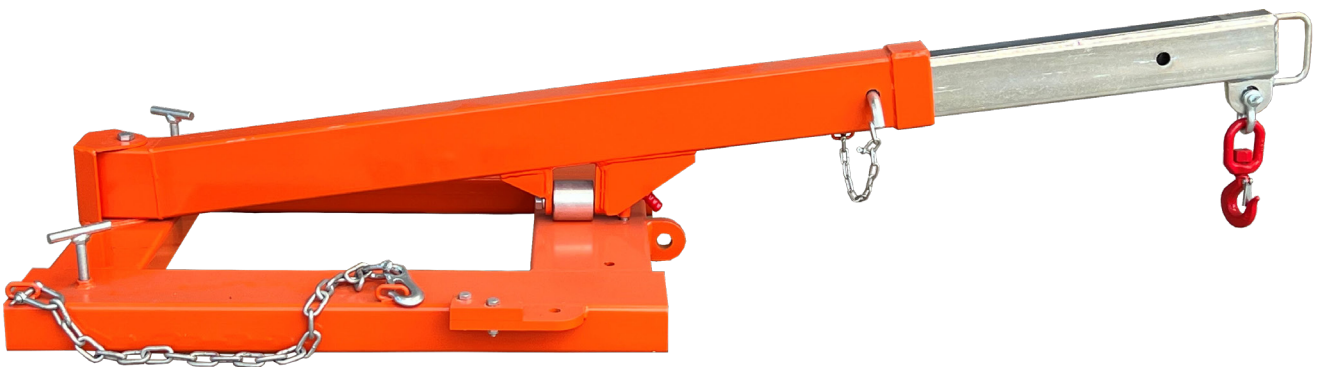

### DESCRIPTION

This versatile forklift attachment has five locking points set at 15 degree increments to conveniently slew a load, avoiding the need to reposition a forklift or telehandler whilst on site.

The Swing Arm Forklift Boom comes in a painted finish and includes a Manual/Certificate, Safety chain and swivel hook.

### FEATURES

- ☒ Boom slews 30 degrees left and right
- ☒ Boom has an 8-degree tilt for extra height
- ☒ Painted finish



# TECHNICAL DATA SHEET

DRUM HANDLER (SPADE) - 400KG

FDH15-503

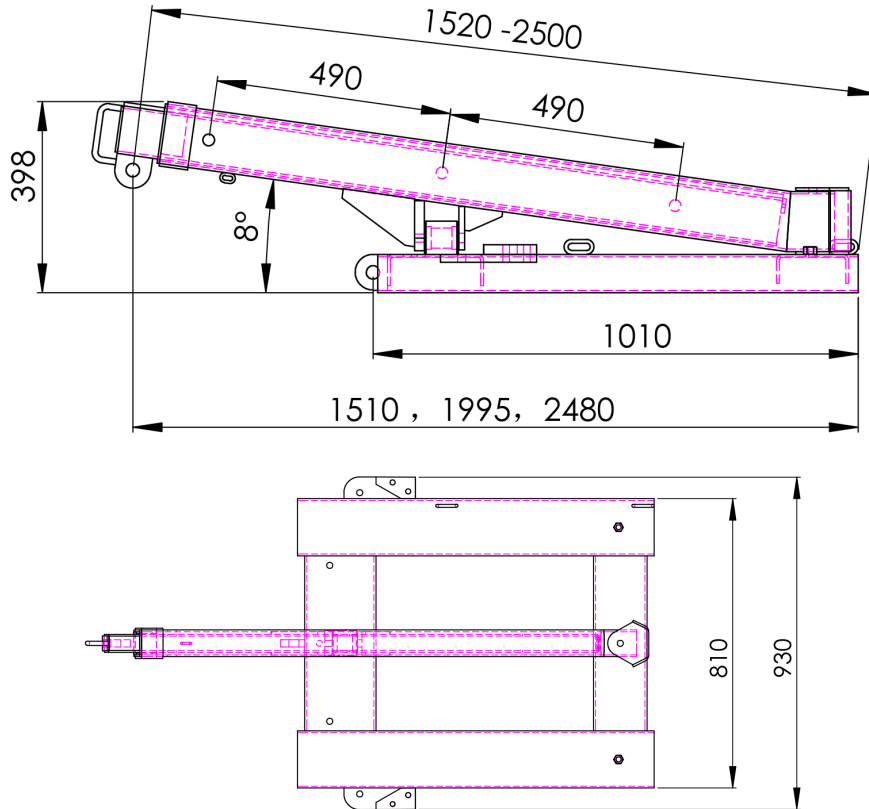

## SPECIFICATIONS

DESCRIPTION	WORKING LOAD LIMIT (WLL) PER POSITION			
Position	1	2	3	4
Extension (mm)	1010	1510	1995	2480
WLL (KG)	2000	1200	800	600

WORKING LOAD LIMIT (KG)	HORIZONTAL CENTRE OF GRAVITY (MM)	VERTICAL CENTRE OF GRAVITY (MM)	POCKET SIZE (MM)	POCKET CENTRES (MM)	UNIT WEIGHT (KG)
2000	660	60	150 x 70	650	110

## CERTIFICATION

Manufactured strictly in accordance with the following standards:

STANDARD	DESCRIPTION
AS 3990	Structural Steel for Mechanical Engineering
AS 2359.1	Powered Industrial Trucks
AS 2359.2	Powered Industrial Trucks Operations
AS 1554.1	Structural Steel Welding