

Forklift Rotator – Hydraulic

Stratalign Forklift Rotators are designed to increase the functionality of your fork hoist or telehandler, allowing it to quickly invert loads with a 360° rotating motion, whilst retaining the standard forklift use for palletized and conventional loads.

Commonly used for bin turning, pouring, and emptying in food manufacturing, chemical manufacturing, waste management, recycling, construction sites and general manufacturing industries.

Features:

- Full 360° rotation in both directions.
- Wide range of fork position options
- Drive motor is concealed to protect it from damage
- Designed to give excellent visibility of forks for the operator
- Uses one additional hydraulic circuit

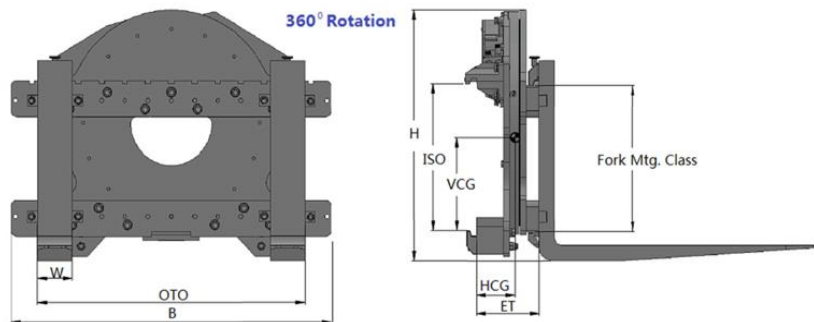

Specifications:

Model	Capacity @ Load Centre	OTO (mm)	B (mm)	Mtg Class	Weight (kg)
SRRB-25G-02C	2500KG @ 500mm	1030	1120	2	311
SRRB-35G-01C	3500KG @ 500mm	1030	1120	3	389

NB: Supplied without forks and hydraulic hosing.

NB: A full range of other sizes are available on request