

THREE PHASE, SINGLE SPEED (WITH & WITHOUT TROLLEY)

250KG - 5000KG

Body: Light Aluminium alloy body which is light but very hard wearing. Fit for use in extreme work environments with a high heat dissipation rate. IP 54 Protection rating.

Anti-phase Protection Device: An electrical control system which prevents the hoist from working if the incoming power supply is not wired to the hoist correctly.

Limit switches: Upper and lower limit switches are installed as standard equipment to prevent the over raising or lowering of the load.

Pendant: 24V safety protection with light touch push buttons.

Braking Mechanism: The magnetic braking system responds instantly and will safely support the load during a power failure.

Chain Bag: Manufactured from tough and durable PVC product.

Load Chain: FEC80 chains are manufactured from a special alloy steel and when hardened have a super-tough carbonised outer surface.

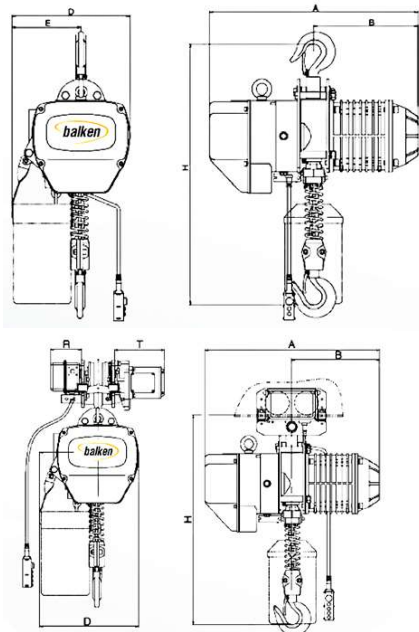

Model	BECH-30256	BECH-3056	BECH-316	BECH-326	BECH-336	BECH-356
Capacity (t)	0.25	0.5	1	2	3	5
Lifting Speed (m/min)	7.2	7.2	6.6	6.6	4.4	2.7
Motor Power (kw)	0.8	0.8	1.5	3.0	3.0	3.0
Rotation Speed (r/min)	1440					
Insulation Grade	F					
Power Supply	3P 220V-690V					
Control Voltage	24V / 36V / 46V					
No. of chain	1	1	1	1	2	2
Spec of Load Chain	ø6.3	ø6.3	ø7.1	ø10.0	ø10.0	ø11.2
Dimensions	A	460	460	520	615	615
	B	230	230	260	295	295
	D	288	288	300	430	430
	E	178	178	176	265	265
	H	530	530	650	800	845
with Trolley	635	635	650	770	830	
Net Weight (kg)	47	47	61	115	131	151